

G750EU .75A 6V&12V



Auto | Marine | RV | Powersport | Lawn & Garden



UltraSafe[®] Battery Charger[™]

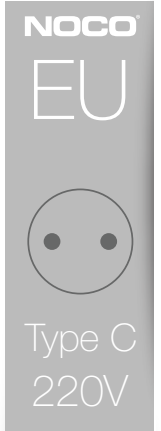

Charge Fully Drained
Batteries Up To **30Ah**.
Maintain All Battery Sizes.

ATVs, Lawn Mowers, Motorcycles, Cars, Trucks,
Boats, RVs, Tractors, Equipment, And More.

Ultra-compact, rugged, and portable **UltraSafe[®]** Smart Charger.
Features **spark proof technology** and **reverse polarity protection**. Charges **2X faster** than ordinary chargers. Stay connected 24/7 with **zero overcharge**.

-  **Start-Stop.**
Counteracts increased cyclic energy demands placed on batteries in micro-hybrid vehicles.
-  **Energy Save.**
Minimizes energy consumption when full power is not needed.
-  **Recovery.**
Applies a high-voltage pulse charge when low-voltage, sulfation, or lost capacity is detected.
-  **Firewall.**
Multi-level safety barrier prevents unsafe and abnormal conditions.
-  **Thermal Monitor.**
Internal temperature sensors adjust charge based on ambient climate.
-  **Rugged.**
Dirt, water, UV, impact and crush resistant.
-  **Optimization.**
Stabilizes internal battery chemistry for increased performance and longevity.
-  **Safe.**
Protects against reverse polarity, sparks, over-charging, overcurrent, open-circuits and overheating.
-  **CANBUS.**
Automatically enables the charging port to charge CANBUS systems.
-  **Load Tracking.**
Dynamically changes charge current when a load is placed on the battery.
-  **Memory.**
Returns to last-selected mode when restarted.
-  **Maintenance Plus.**
Keeps the battery fully charged without over-charging, indefinitely.
-  **Diagnostics.**
Intuitive visual diagnostic tool for detecting reverse polarity, low-voltage or damaged batteries.
-  **Interactive.**
Alters the charging process based on organic battery feedback.

Charge **6V&12V** Batteries Up To 40Ah. Maintain All Battery Sizes.



Charging Modes

Mode	Explanation	12V NORM	14.5V 750A 2-30Ah Batteries For charging 12-volt Wet Cell, Gel Cell, Enhanced Flooded, Maintenance-Free and Calcium batteries. When selected, a white LED will illuminate.
Standby	No Power In standby mode, the charger is not charging or providing any power to the battery. Energy Save is activated during this mode, drawing microscopic power from the electrical outlet. When selected, an orange LED will illuminate.	6V NORM Press & Hold	7.25V 750A 2-30Ah Batteries For charging 6-volt, Wet Cell, Gel Cell, Enhanced Flooded, Maintenance-Free and Calcium batteries. When selected, a white LED will illuminate.

Technical Specifications

Input Voltage AC:	Type C, 220-240V VAC, 50-60Hz	Type of Batteries:	6V & 12V
Working Voltage AC:	Type C, 220-240V VAC, 50-60Hz	Battery Chemistries:	Wet, Gel, MF, CA, EFB, AGM
Efficiency:	85% Approx.	Battery Capacity:	2-30Ah (12V), 2-30Ah (6V), Maintains All Battery Sizes
Power:	13W Max		
Low-Voltage Detection:	2V (12V), 2V (6V)	Housing Protection:	IP60
Back Current Drain:	<5mA	Cooling:	Natural Convection
Ambient Temperature:	0°C to +40°C, 32°F to +104°F	Dimensions (LxWxH):	4.4 x 2.7 x 1.5 in (112 x 69 x 38mm)
Charger Type:	8 Step, Smart Charger	Weight:	0.49 Pounds (0.22 kg)

Charging Steps

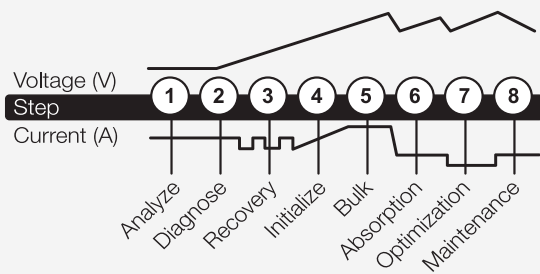

What's In The Box

- G750 Smart Charger
- Battery Clamp Connectors w/ Integrated Eyelets
- User Guide and Information Guide & Warranty

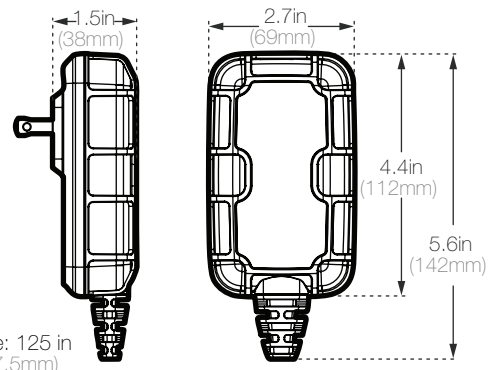

Retail Packaging:

Dimensions: 6.46"x3.78"x4.02"
(164 x 96 x 102mm)

Weight: 1.08lbs (0.49kg)

UPC: 0-46221-14008-8

Inner Carton:

Dimensions: 6.77"x4.09"x4.53"
(172 x 104 x 115mm)

(cont'd.) Weight: 1.26lbs (0.57kg)

Master Carton:

Dimensions: 17.24"x14.25"x9.84"
(438 x 362 x 250mm)

Weight: 21.65lbs (9.82kg)

Quantity: 16

UCC: 10046221140085

Units Per Pallet: 576 Units



CONFORMS TO EN60335-1, EN60335-2-29, EN62233, EN55014-1, EN55014-2, EN61000-3-2, EN61000-3-3

DC Cable: 125 in
(317.5mm)

The NOCO Company
30339 Diamond Parkway, #102
Glenwillow, OH 44139 | USA
1.800.456.6626

no.co

NOCO
Since 1914